

# SI-2107A

## Mini Dual Action Sander

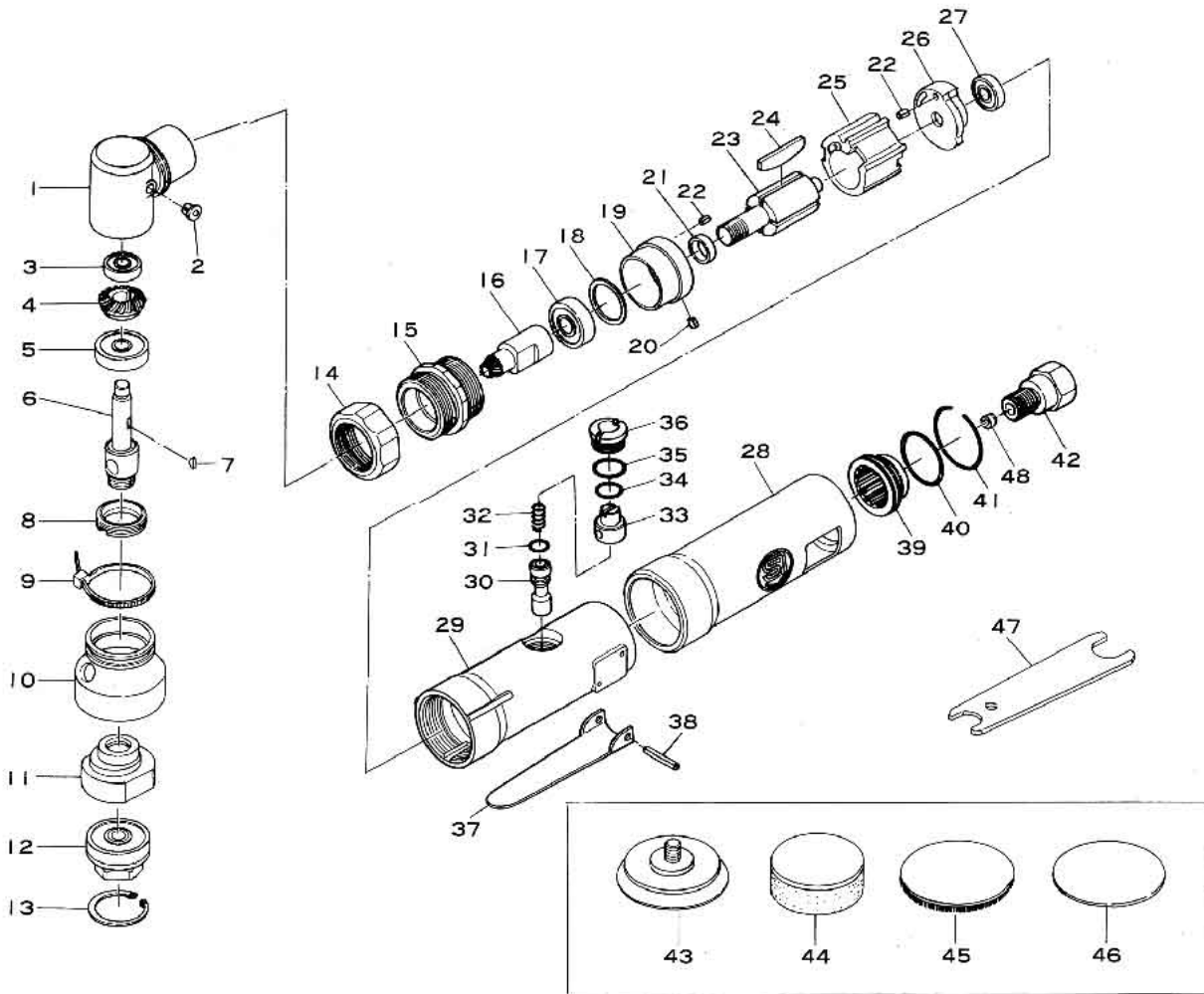

Ref. No.	Parts No.	Description	Q'ty	Ref. No.	Parts No.	Description	Q'ty
1	115-31	Angle Head	1	25	330-17	Cylinder	1
2	1071C-16	Grease Plug	1	26	610-12	Rear Plate	1
3	R4-ZZ	Ball Bearing	1	27	696-ZZ	Ball Bearing	1
4	115L-2A	Bevel Gear	1	28	117-1	Housing Cover	1
5	608-LLU	Ball Bearing	1	29	612-1	Motor Housing incl. Valve Bush (330-4)	1
6	115BD-1	Spindle	1	30	330-5	Valve Stem	1
7	115-36	Key	1	31	P-4	O-Ring	1
8	115-32	Spindle Nut	1	32	350-7	Valve Spring	1
9	115BD-3	Band	1	33	330-8A	Air Regulator	1
10	115BD-2	Balancer Cover	1	34	P-8	O-Ring	1
11	262-19A	Balancer	1	35	P-10	O-Ring	1
12	262-20M	Random Shaft Assy. incl. Ball Bearing, Spacer & Felt Ring (6000-ZZ, 262-22A, 262-23A)	1	36	330-10	Valve Screw	1
13	BO-26	Retaining Ring	1	37	350-2	Throttle Lever	1
14	115-27	Angle Head Coupling Nut	1	38	30-24	Roll Pin (3-24mm)	1
15	115-26	Motor Clamp Nut	1	39	610-29	Deflector	1
16	115L-1A	Pinion Gear	1	40	620-28	O-Ring	1
17	608-ZZ	Ball Bearing	1	41	610-30	Retaining Ring	1
18	330-20	Shim (0.03mm)	1	42	610-2SC	Inlet Bushing incl. Screen (680-28A) & Retainer (CRTW-12)	1
19	115-19	Front Plate	1	43	262-21MD	48φ mm Velcro Pad	1
20	25-3.5	Roll Pin (2.5-3.5mm)	1	44	M-20x60/B	60φ mm Sponge Buff	1
21	330-18	Collar	1	45	M-60	60φ mm Wool Buff	1
22	25-5	Roll Pin (2.5-5mm)	2	46	SHP-50M	50φ mm Sanding Paper #80	3
23	330-15	Rotor	1	47	330-28	Spanner Wrench (11x17mm)	1
24	330-16	Rotor Blade	4	48	118-4	Restrictor	1